

M 120-150-160 C



www.altodis.fr



Looking for quality.



M 120-150-160 C



VENTE LOCATION MAINTENANCE DE MATÉRIELS DE MANUTENTION ET BTP

MULHOUSE (Siège)
03 89 63 41 10
COLMAR
03 89 20 91 74
SÉLESTAT
03 88 92 92 24
STRASBOURG
03 88 68 18 20
BESANÇON
03 81 21 64 36

altodis.fr

MORA

M 120-150-160 C



MORA

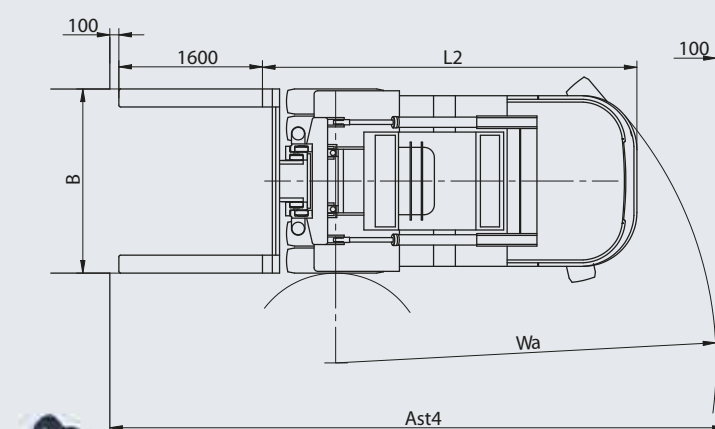
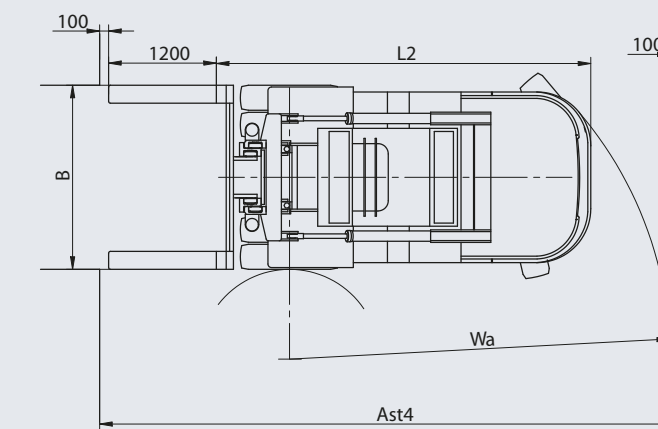
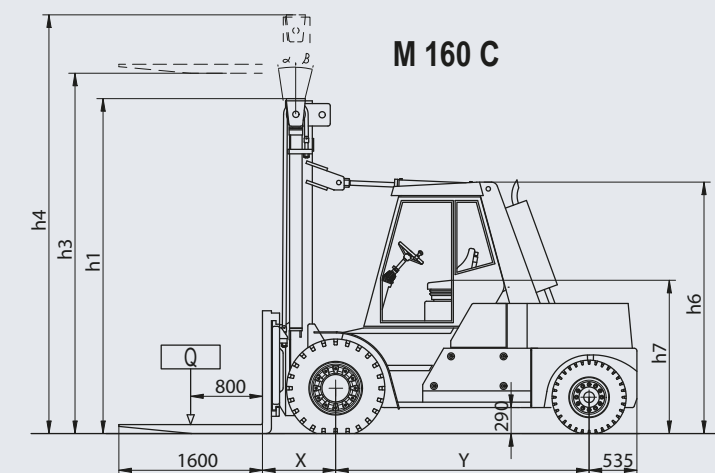
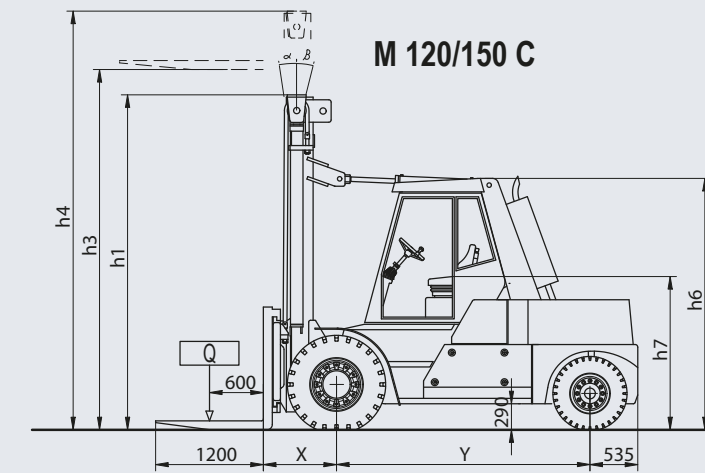
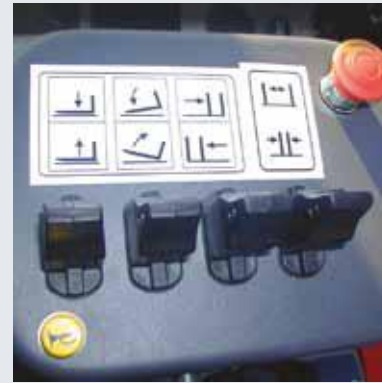
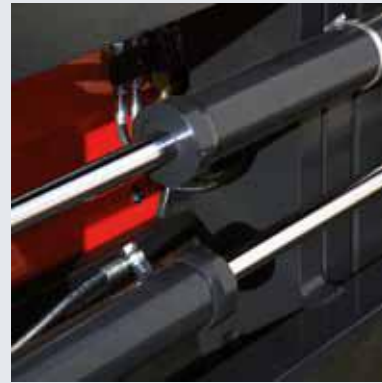

Caratteristiche		MORA M120C	MORA M150C	MORA M160C	
1 Casa costruttrice	Sigla	MORA	MORA	MORA	
2 Modello	Tipo	M120C	M150C	M160C	
3 Portata	Q Carico nominale	12000	15000	16000	
4 Baricentro	C distanza	600	600	800	
5 Tipo motore	Elettrico-diesel-benzina-GPL	Diesel	Diesel	Diesel	
6 Guida	A mano-a piede-in piedi-seduto	Seduto	Seduto	Seduto	
7 Gomme	S-Superel. --P-Pneum. Ant/Post	S/S	S/S	S/S	
8 Ruote (x=motrici)	Anteriori e posteriori	4x/2	4x/2	4x/2	
9 Alzata	h3 Altezza	4000	4000	4000	
10 Montanti duplex	h2 Alzata libera normale	-	-	-	
11	h5 Alzata libera speciale	-	-	-	
12 Piastra porta-forche	Secondo DIN 15173 A/B/no	No	No	No	
13 Forche	Forche	1200x200x90	1200x200x90	1200x200x100	
14 Inclinazione	in avanti/indietro	5/12°	5/12°	5/12°	
15 Dimens. di massima	L2 lunghezza incluso dorso forche	4070	4170	4270	
16	B Larghezza	2050	2050	2050	
17	h1 Altezza minimo ingombro	3275	3275	3630	
18	h4 Altezza massimo ingombro	5275	5275	5630	
19	h6 Altezza tettuccio	2800	2800	2800	
20	h7 Altezza sedile	1710	1710	1710	
21	Wa	4140	4240	4340	
22	Distanza del carico	x Dal centro assale anteriore	815	815	825
23	Corridoio per cu. 90°	Ast3	3480	3580	3650
24	Corridoio	Ast4	6355	6455	6550
25	Velocità	Traslazione con/senza carico	8/12	8/12	8/12
26		Sollevamento con/senza carico	0,23	0,22	0,13/0,16
27		Abbassamento con/senza carico	0,3	0,3	0,3
28	Sforzo di traino	Con/senza carico	6300/7500	6300/7400	6100/7400
29		Max 5 min. per carrelli elettrici	-	-	-
30	Pendenza superabile	Con/senza carico	10/20	9/20	8/18
31	Pend. max. sup.le	Con/senza carico max 5 1' carr. el.	-	-	-
32	Peso proprio	Batteria inclusa	17080	19000	22700
33	Peso sugli assali	Senza carico ant./post.	8000/9080	8000/11000	10300/12400
34		Con carico ant./post.	26242/2838	30526/3474	35450/3250
35		Numero	4/2	4/2	4/2
36	Pneumatici	Dimensioni anteriori	12.00-20	12.00-20	12.00-20
37		Dimensioni posteriori	350-15	350-15	350-15
38	Passo	y	2720	2820	2920
39	Carreggiata	Centro ruote ant./post.	1450/1600	1450/1600	1450/1600
40	Alt. min. da terra	Con carico punto più basso	210	210	210
41		Con carico metà passo m2	290	290	290
42	Freni	Di esercizio/stazionamento	Pedale/a mano	Pedale/a mano	Pedale/a mano
43		Mecc/draulico/elettrico/pneum.	Idraulico	Idraulico	Idraulico
44		Tipo	Avviamento	Avviamento	Avviamento
45	Batteria	Volt/Ampère ora	24/143	24/143	24/143
46		Peso	-	-	-
47		Traslazione potenza	-	-	-
48	Motore elettrico	Sollevamento potenza	-	-	-
49		Idroguida potenza	-	-	-
50		Costruttore tipo	Volvo TAD571VE	Volvo TAD571VE	Volvo TAD571VE
51		Potenza DIN 70020	129	129	129
52	Motore endotermico	Numero di giri DIN 70020	2200	2200	2200
53		Tempi/cilindri/cilindrata	4/4/5100	4/4/5100	4/4/5100
54		Consumo carburante	-	-	-
55	Frizione	Tipo	-	-	-
56	Cambio	Tipo	Avanti/Indietro	Avanti/Indietro	Avanti/Indietro
57		Numero marce avanti/indietro	-	-	-
58	Trasmissione	Sistema	Idrostatica	Idrostatica	Idrostatica
59	Pressione di lavoro	Per attrezzature	165	175	200

Features		MORA M120C	MORA M150C	MORA M160C	
1 MANUFACTURER	Initials	MORA	MORA	MORA	
2 Model	Type	M120C	M150C	M160C	
3 Capacity	Q. Rated capacity	12000	15000	16000	
4 Load center	C distance	600	600	800	
5 Power type	Electric (battery)-diesel-petrol-LPG	Diesel	Diesel	Diesel	
6 Control type	Hand-pedestrian-stand-sit	Sit	Sit	Sit	
7 Tyre equipment	V-Solid P-Pneumatic front/rear	S/S	S/S	S/S	
8 Wheels (x driven)	Front/rear	4x/2	4x/2	4x/2	
9 Lift	Lift height	4000	4000	4000	
10 Duplex mast	h2 normal free lift	-	-	-	
11	h5 special free lift	-	-	-	
12 Fork head	norm DIN 15173 A/B/no	No	No	No	
13 Forks	Length-width-thickness	1200x200x90	1200x200x90	1200x200x100	
14 Tilt angle	forward/backward	5/12°	5/12°	5/12°	
15 Overall dimensions	L2 length to face of forks	4070	4170	4270	
16	B width	2050	2050	2050	
17	h1 Height, upright lowered	3275	3275	3630	
18	h4 Height, upright extended	5275	5275	5630	
19	h6 overhead guard height	2800	2800	2800	
20	h7 seat height	1710	1710	1710	
21	Turning radius	Wa	4140	4240	4340
22	Load distance	x from centre of front axle	815	815	825
23	Aisle cu 90°	Ast3 with st. forks	3480	3580	3650
24	Aisle	Ast4 with st. forks	6355	6455	6550
25	Speeds	Travel speed loading/unloading	8/12	8/12	8/12
26		Lift speed loading/unloading	0,23	0,22	0,13/0,16
27		Lowering speed loading/unloading	0,3	0,3	0,3
28	Drawbar pull	Loading/Unloading	6300/7500	6300/7400	6100/7400
29	Max drawbar pull	Loading/Unloading (electric 5 min.)	-	-	-
30	Gradeability	Loading/Unloading	10/20	9/20	8/18
31	Max.gradeability	Loading/Unloading (electric 5 min.)	-	-	-
32	Total weight empty	With battery	17080	19000	22700
33	Axle loading	Unloading front/rear	8000/9080	8000/11000	10300/12400
34		Loading front/rear	26242/2838	30526/3474	35450/3250
35		Number front/rear	4/2	4/2	4/2
36	Tyres	Front sizes	12.00-20	12.00-20	12.00-20
37		Rear sizes	350-15	350-15	350-15
38	Wheelbase	y	2720	2820	2920
39	Tread	Centre of tyres front/rear	1450/1600	1450/1600	1450/1600
40	Ground clearance	Loading at lowest point	210	210	210
41		Loading centre of wheelbase	290	290	290
42	Brakes	Foot/Parking	Pedal/Hand	Pedal/Hand	Pedal/Hand
43		Mech.,hydraulik,elec.,pneum.	Hydraulic	Hydraulic	Hydraulic
44		Type	Start	Start	Start
45	Battery	Volt/Amp/hrs	24/143	24/143	24/143
46		Weight	-	-	-
47		Side-shift/power	-	-	-
48	Electric motors	Hoist/power	-	-	-
49		Hoist/power	-	-	-
50		Make model	Volvo TAD571VE	Volvo TAD571VE	Volvo TAD571VE
51		Output DIN 70020	129	129	129
52	Internal Combustion	Number of revol. DIN 70020	2200	2200	2200
53		Stroke/No. of cylinders/Displ.	4/4/5100	4/4/5100	4/4/5100
54		Fuel consumption	-	-	-
55	Clutch	Type	-	-	-
56	Gear change	Type	2 Pedal for./back.	2 Pedal for./back.	2 Pedal for./back.
57		Number of speeds forw./rev..	-	-	-
58	Transmission	Type	Hydrostatic	Hydrostatic	Hydrostatic
59	Working pressure	For attachments	165	175	200